

Technical specification

Operating time	12 seconds
Duty cycle	100%
Boom weight	27.0kg (6.0m) 58.0kg (9.0m) 71.5kg (12.0m)
Controller	MO 63 or MO 64
Housing unit material	Aluminium
Housing unit dimensions (l/w/h)	720mm x 656mm x 1250mm
Operating temperature	-10c to +70c optional -40c is available
Protection rating	IP 44
Power supply	230V/50Hz or 115V/60Hz
Total weight (Kg)	452-547
Foundation dimension	1200mm x 1200mm x 1200mm
Boom Connector	Middle/Centered

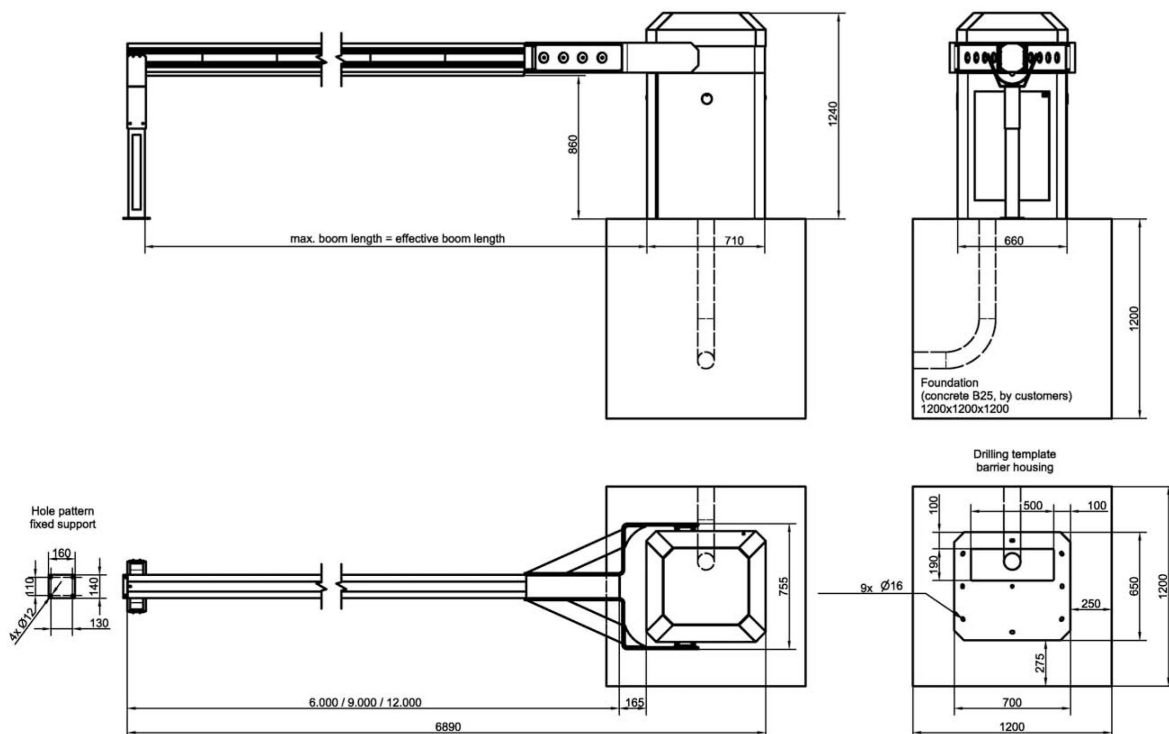

www.autopa.co.uk
+44 (0)1788 550556

AUTOPA Limited
Cottage Leap, Rugby, Warwickshire CV21 3XP

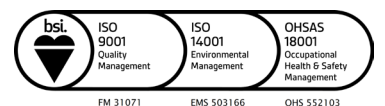

FM 31071 EMS 503166 OHS 552103