



Clifton Cycle Stand Galvanised, Galvanised & Colour or Stainless



The Clifton Cycle stand is a variant of the ever popular Sheffield Cycle Stand which is a familiar sight throughout the UK. The Clifton Cycle Stand has an additional diagonal tube between the legs which allows the frame of the bicycle to be secured by the users own security lock.

Suitable for securing two bicycles.

The practical and durable nature of the Clifton Cycle Stand stand ensures that the stand will complement any environment.

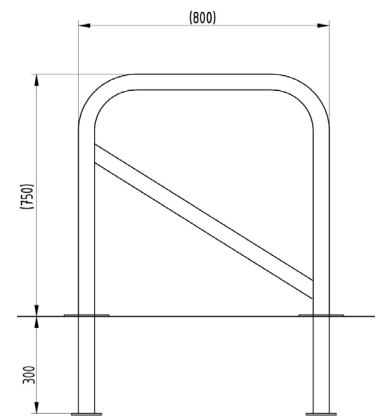

<u>Part Number</u>	<u>Description</u>	<u>Weight (kg)</u>
138 515 135	Galvanised - Concrete In	11kg
138 515 131	Galvanised - Bolt Down	10kg
138 515 136	Galvanised & Black - Concrete In	11kg
138 515 132	Galvanised & Black - Bolt Down	10kg
138 515 137	Galvanised & Colour - Concrete In	11kg
138 515 133	Galvanised & Colour - Bolt Down	10kg
138 515 139	Stainless Steel Grade 304 - Concrete In	11kg
138 515 134	Stainless Steel Grade 304 - Bolt Down	9kg

Product details

- 48mm diameter tube
- 750mm x 800mm (height x length)
- Concrete in 300mm (below ground)
- Round flange plate – 133mm x 5mm
- Each stand requires 6 bolts (bolt down)

Installation & use

Bolt down to a suitable concrete surface.
Telescopic, removable and concrete in are supplied with welded fixing spikes to ensure firm ground anchorage into concrete.
Telescopic, removable and concrete in require a suitable excavated hole for installing into concrete.
Products are guaranteed for 12 months (if installed and used correctly).



www.autopa.co.uk
+44 (0)1788 550556

AUTOPA Limited
Cottage Leap, Rugby, Warwickshire CV21 3XP

