

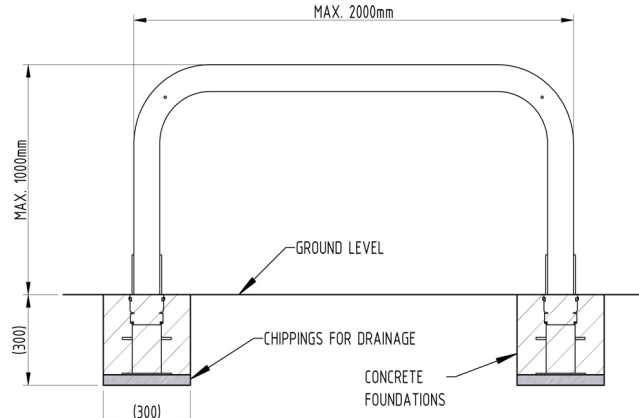

Key Locking Removable Perimeter Barrier

76mm Galvanised Steel



Key Locking Removable Perimeter Barriers are designed to help secure site perimeters and provide a permanent obstacle to vehicle access. Best suited to sites where aesthetics, security and flexibility are equally important.

These perimeter barriers are commonly found outside car showrooms, helping to protect the cars on the forecourt without impeding a customer's view of the vehicles.

This style of removable perimeter barrier achieved Sold Secure. Sold Secure products are evaluated using methods approved by the Police and the Home Office.

Tested and approved by Sold Secure.

This product has achieved Secure by Design status.

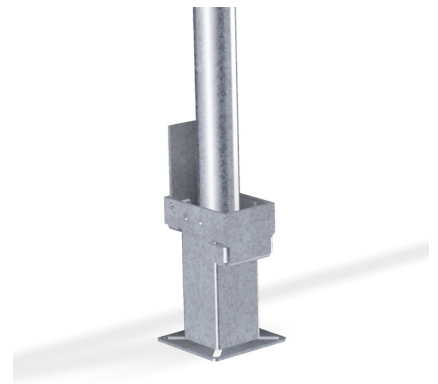

Part Number	Description	Lift Weight (kg)	Weight (kg)
138 179 751	500 x 1000 Galvanised - Removable	15kg	27kg
138 179 757	500 x 1500 Galvanised - Removable	18kg	30kg
138 179 762	500 x 2000 Galvanised - Removable	21kg	33kg
138 179 766	750 x 1000 Galvanised - Removable	18kg	30kg
138 179 773	750 x 1500 Galvanised - Removable	21kg	33kg
138 179 779	750 x 2000 Galvanised - Removable	24kg	36kg
138 179 781	1000 x 1000 Galvanised - Removable	21kg	33kg
138 179 789	1000 x 1500 Galvanised - Removable	24kg	36kg
138 179 793	1000 x 2000 Galvanised - Removable	27kg	39kg



Secured by Design



Police Preferred Specification

Product details

- Sold Secure
- Available in either 76mm or 90mm
- Radial Pin Tumbler
- Colour options available extra
- Socket - 270mm (below ground)

Installation & use

Bolt down to a suitable concrete surface.
 Telescopic, removable and concrete in are supplied with welded fixing spikes to ensure firm ground anchorage into concrete.
 Telescopic, removable and concrete in require a suitable excavated hole for installing into concrete.
 Products are guaranteed for 12 months (if installed and used correctly).



www.autopa.co.uk
 +44 (0)1788 550556

AUTOPA Limited
 Cottage Leap, Rugby, Warwickshire CV21 3XP

